

OTARI MX-80 TLS-4000

INTERFACE DOCUMENTATION

Interface number : 1.812.460.20

IF - Doc number : 10.27.1580

Prepared and edited by
STUDER INTERNATIONAL
TECHNICAL DOCUMENTATION
Althardstrasse 10
CH-8105 Regensdorf-Zürich
Switzerland

We reserve the right to make alterations

Copyright by WILLI STUDER AG
Printed in Switzerland

Order No: 10.27.1580 (Ed. 0690)

STUDER is a registered trade mark of STUDER INTERNATIONAL AG Regensdorf

Summary

1	General.....	1
1.1	Modules, part numbers	1
1.2	Slave models.....	1
1.3	Software	1
2	Start-up procedure	2
2.1	TLS4000/interface requirements	2
2.2	Slave machine requirements.....	2
2.3	Cabling TLS 4000 / OTARI MX-80	2
2.4	Quick test, alignment.....	2
3	Operating instructions.....	3
3.1	Technical data.....	3
3.2	List of functions.....	3
3.3	DIL switches.....	4
3.4	Supplementary functions on the SLAVE CONTROL B connector.....	4
3.5	Pilot LEDs.....	5
3.6	Test points.....	5
3.7	Application notes	5
4	Service documentation.....	6
4.1	Diagrams.....	6
4.2	Component arrangement	9
4.3	Component position list	10
4.4	Signal description, slave connector A	11
4.5	Slave connector B	12
4.6	IF cable (drawing, wiring list)	13

1 General

1.1 Modules, part numbers

Order Number

-
- | | |
|----------------------------------------------------------------|---------------|
| ■ Interface kit, complete
(Interface, cable, documentation) | 21.812.460.20 |
| ■ Interface assembly (HW, SW) | 1.812.460.20 |
| IF software set | 1.812.982.20 |
| IF cable 5 m | 1.023.764.00 |

1.2 Slave models

- OTARI MX-80-24H (multichannel audio tape recorder)
OTARI MX-80-32H
- Machines with compatible control: -

1.3 Software

- Initial version index 20 1.812.982.20 20/89

2 Start-up procedure

2.1 TLS4000/interface requirements

Order Number

- Synchronizer board later than 1.812.320.23
- Interface: correctly set DIL switches (see section 3.3)

2.2 Slave machine requirements

- MX-80: Switch on transport control PCB
(Operation and maintenance manual, Section 6.2.4)
- SW3-2 OFF Record punch out
(transition REC/PLAY -> PLAY with play command)
- SW3-4 ON Tacho pulse rate switch
(200 Hz at 30 ips)
- SW4-1 OFF Rehearse operation
(through parallel I/O connector)
- Channel remote control CB123 or CB124:
Speed mode selector switch in EXT position

2.3 Cabling TLS 4000 / OTARI MX-80

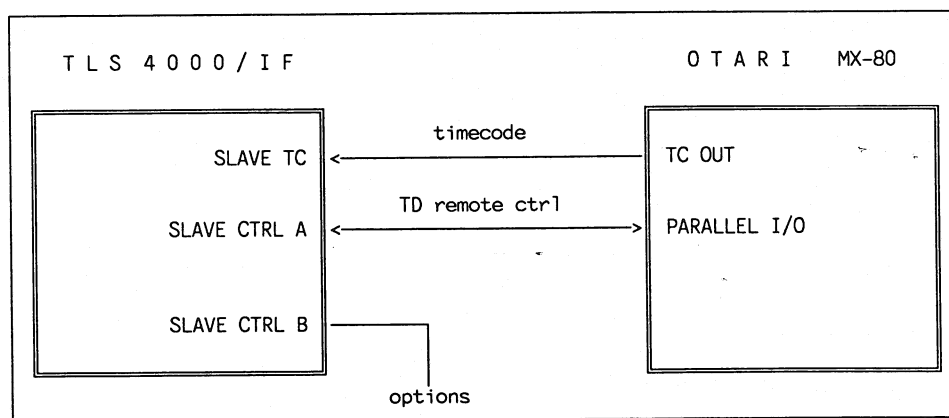

2.4 Quick test, alignment

- After the power has been switched on, both LEDs must be dark (also refer to Section 3.5).
- The correct wiring of the move pulses can be checked by displaying the slave time (LCU or controller).

3 Operating instructions

3.1 Technical data

- Slave type:
SMPTE/EBU TC machine with move pulse information without code in spooling mode
 - GOTO function with PLAY-STOP sequence
 - Parking in LOCK mode with edit lead
 - CHASE-PLAY transition with preroll parking
- Tape deck control:
with parallel remote control
- Capstan servo control:
frequency control, nom. 9600 Hz, $\pm 50\%$
- Move pulse information:
clock/direction: 200 Hz at 30 ips
- Typical lockup time
(from CUED condition, master start - SYNC) : < 3 sec
(from CHASE 10* v_{nom} , master start - SYNC) :
- Drop-in delay: 120 msec (30 ips), 176 msec (15 ips)
Drop-out delay: 148 msec (30 ips), 188 msec (15 ips)
- TC compensation: 0 msec

3.2 List of functions

Tape deck functions:

- STOP
PLAY, REC Nominal (MX80 reference loop via IF)
Ext. varispeed (TLS reference, $\pm 50\%$)
EDIT Identical to STOP
FORW, REW Variwind speed with directional control signal, 0 ... v_{mx} ,
Lifter defeat up to 4.5 v_{nom}
SHTLF, SHTLR identical to FORW/REW
- LOC, LOCREL
Locate implemented in interface
- MUTE and REHEARSE
REHEARSE is implemented, the MUTE function is not available.
- EVENT RELAY
Control of this relay is possible (see Section 3.4).

- **CONDITIONAL COMMANDS**
Code-controlled initiation is possible for the following functions:
Tape deck commands STOP, EDIT, PLAY, REC
Relay control EVON, EVOFF
- **STATUS INQUIRY**
The tape deck status of the MX-80 is read via the parallel interface.
- **AUDIO channel remote control, TRANSPARENT commands, KEYBOARD DISABLE**
Not implemented

3.3 DIL switches

The following functions can be set with the DIL switch SZ81:

- **Switch 1: Polarity of the RECEN signal (see Section 3.4)**
Record inhibition is effected by
ON: active signal (LOW)
OFF: inactive signal (HIGH or open)
- All other switches are unused.

3.4 Supplementary functions on the SLAVE CONTROL B connector

- **RECEN (pin 2):**
Record enable for hardware inhibition of the RECORD function. Depending on the setting of DIL switch 1, the inhibition is accomplished either with an active LOW or inactive HIGH signal.
- **REL1 (pin 6), REL2 (pin 7):**
The EVENT relay contact REL1/REL2 can be used for any purpose. It is controlled with the EVON, EVOFF commands via the serial TLS interface.
- **MVCL (pin 21), MVDR (pin 24):**
The move pulse information (outputs, open collector) derived from the slave signals can be used for controlling the master tallies when the MX-80 functions as the master.
MVDR: LOW = reverse
MVCL: The frequency at nominal play speed is 12.5 Hz.

3.5 Pilot LEDs

Two LEDs are located on the interface front panel for indicating the status and errors:

DL 2 1 (front view)

- After power on both LEDs are light. After a brief self-test the detected errors are signalled with flashing LEDs:

DL 2 1 (- LED dark, # LED flashing)

DL2	DL1	
-	#	EPROM checksum error detected
#	-	RAM error detected
#	#	No communication with synchronizer board

- After a successful start the 2 LEDs are used as status indicators.

DL 2 1 (- LED dark, * LED lit)

DL2	DL1	
-	-	Normal quiescent state
-	*	Status of the interface - MX80: Flashes from the time the command is initiated until it has been correctly acknowledged or the expiration of a timeout of approx. One second.
*	-	Status of the interface - synchronizer: Light while the connection is interrupted.

3.6 Test points

- None

3.7 Application notes

- The hardware of the interface is identical to the one of the OTARI MX70 interface (1.812.462.20).
- Move pulse frequency as master tallies (see Section 3.3)

4 Service documentation

4.1 Diagrams

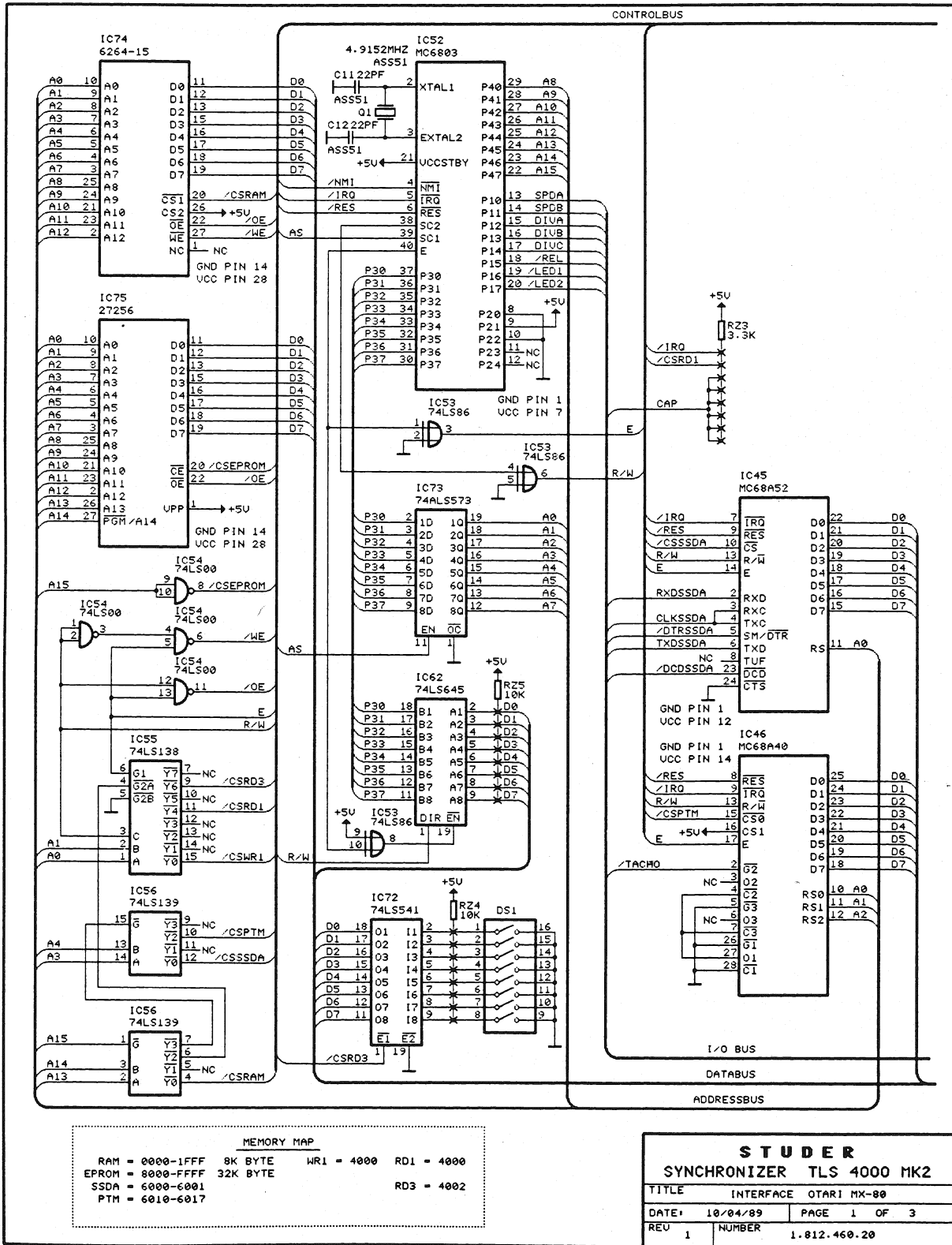

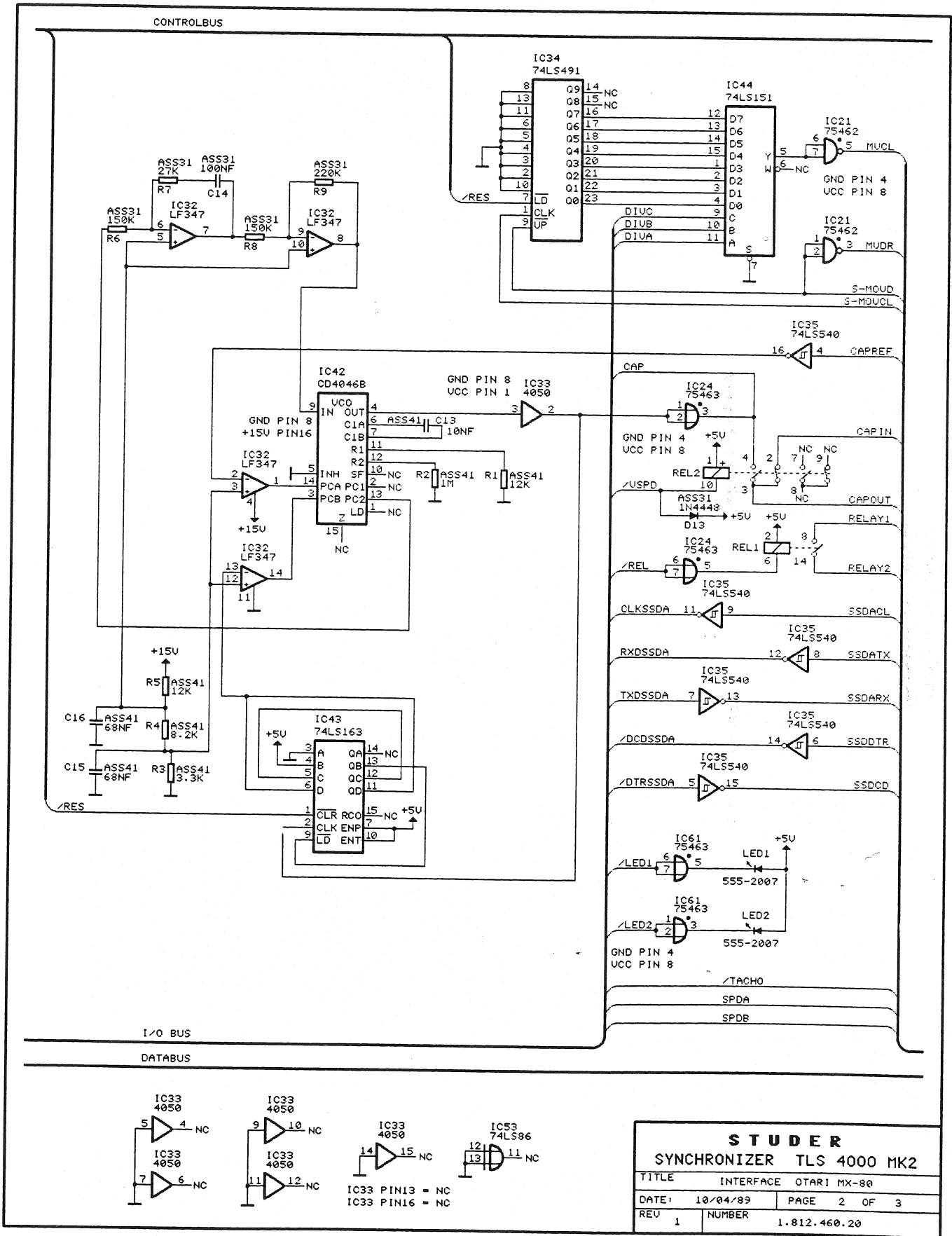

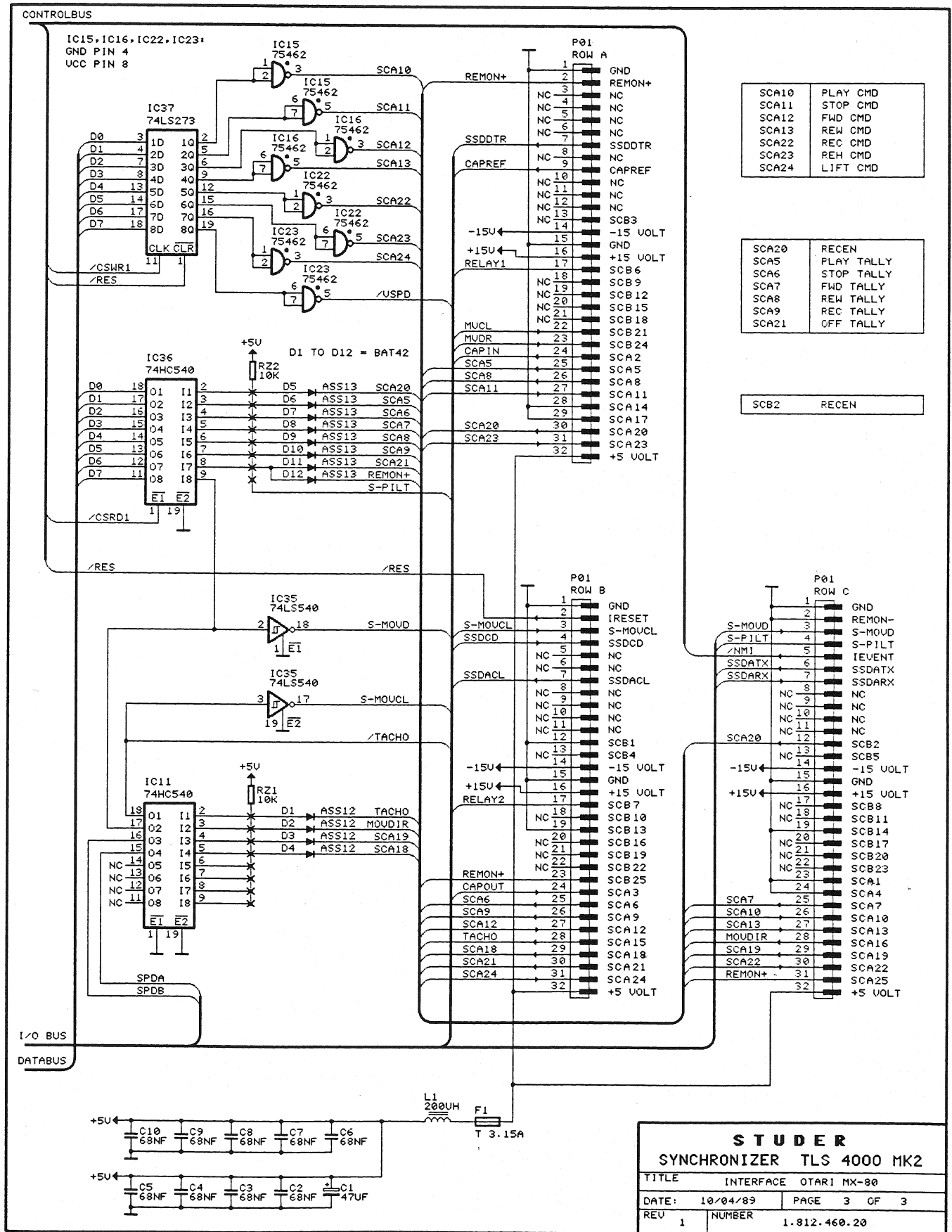

4.2 Component arrangement

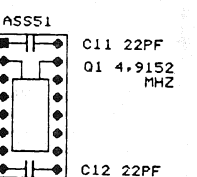
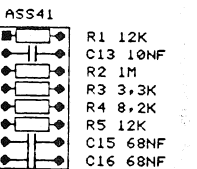
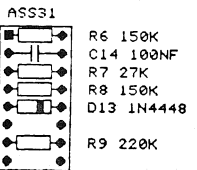
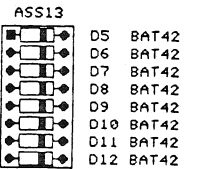
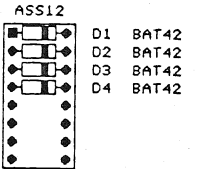
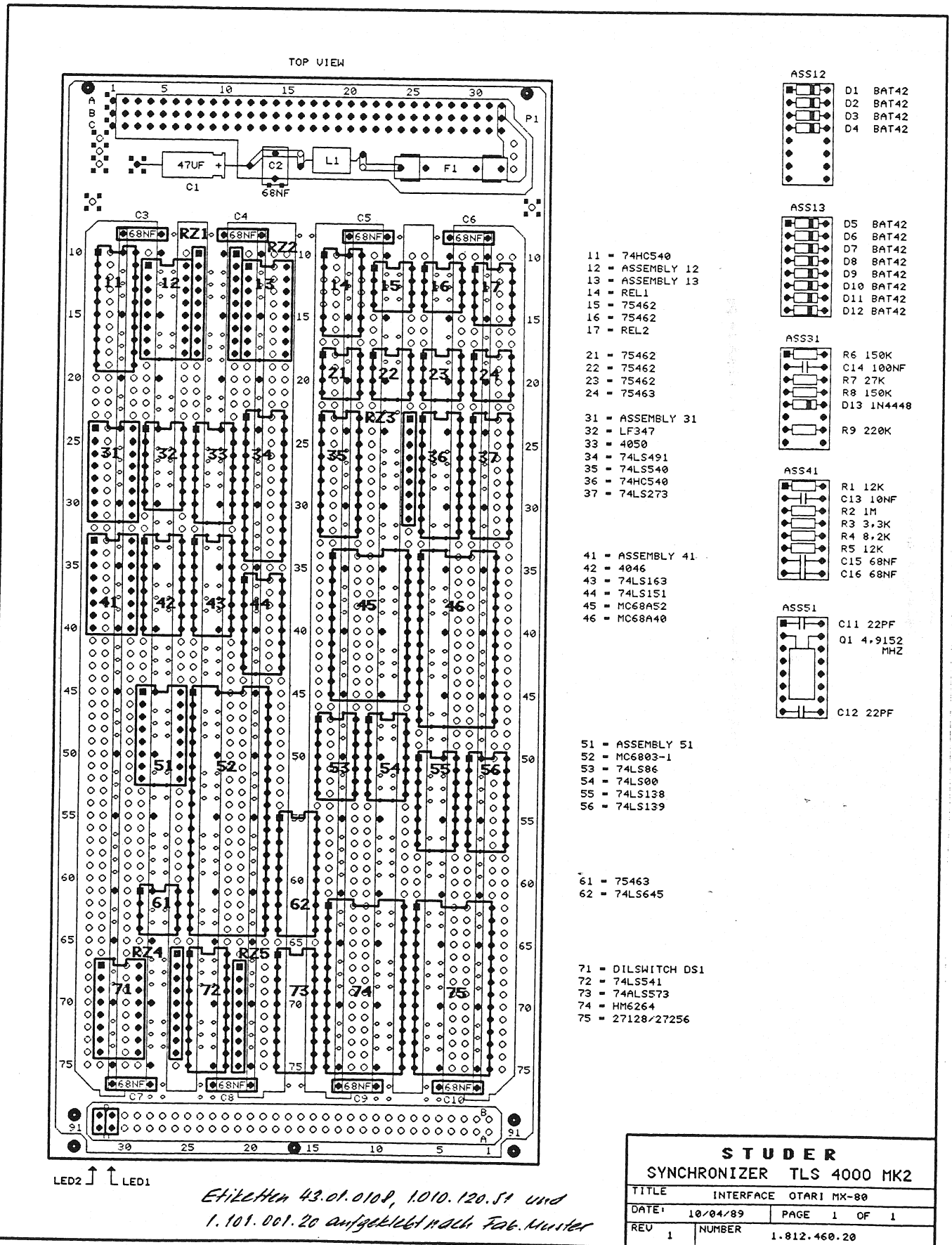

- 11 = 74HC540
- 12 = ASSEMBLY 12
- 13 = ASSEMBLY 13
- 14 = REL1
- 15 = 75462
- 16 = 75462
- 17 = REL2

- 21 = 75462
- 22 = 75462
- 23 = 75462
- 24 = 75463

- 31 = ASSEMBLY 31
- 32 = LF347
- 33 = 4050
- 34 = 74LS491
- 35 = 74LS540
- 36 = 74HC540
- 37 = 74LS273

- 41 = ASSEMBLY 41
- 42 = 4046
- 43 = 74LS163
- 44 = 74LS151
- 45 = MC68A52
- 46 = MC68A40

- 51 = ASSEMBLY 51
- 52 = MC6803-1
- 53 = 74LS86
- 54 = 74LS00
- 55 = 74LS138
- 56 = 74LS139

- 61 = 75463
- 62 = 74LS645

- 71 = DILSWITCH DS1
- 72 = 74LS541
- 73 = 74ALS573
- 74 = HM6264
- 75 = 27128/27256

4.3 Component position list

IF OTARI MX-80 1.812.460.20

Ad	POS.	REF.No.	DESCRIPTION	MANUFACTURER
A....12		1.812.218.00	Assembly 450-12	St
A....13		1.812.218.00	Assembly 450-12	St
A....31		1.812.228.00	Assembly 452-21	St
A....41		1.812.229.00	Assembly 452-41	St
A....51		1.812.201.00	Assembly 120-52	St
C....1		59.25.3470	47 uF -20%, 16V, EL	
C....2		59.99.0205	68 nF -20%, 63V, CER	
C....3		59.99.1200	68 nF 20%, 63V, PET Quantity: 8	
DL....1		50.04.2107	LED red ,555-2007	Di
DL....2		50.04.2107	LED red ,555-2007	Di
F....1		51.01.0122	3.15 AT 250V, 5 * 20	
IC...11		50.06.0540	SN 74 LS 540	
IC...15		50.05.0227	SN 75 462 JG, SN 75 472 P	
IC...16		50.05.0227	SN 75 462 JG, SN 75 472 P	
IC...21		50.05.0227	SN 75 462 JG, SN 75 472 P	
IC...22		50.05.0227	SN 75 462 JG, SN 75 472 P	
IC...23		50.05.0227	SN 75 462 JG, SN 75 472 P	
IC...24		50.05.0203	SN 75 463 JG, DS 75 463	
IC...32		50.09.0104	LF 347 N	
IC...33		50.07.0050	CD 4050 BE, MC 14050 BCP ,A RCA,MOT	
IC...34		50.06.0491	SN 74 LS 491 NS	
IC...35		50.06.0540	SN 74 LS 540	
IC...36		50.06.0540	SN 74 LS 540	
IC...37		50.06.0273	SN 74 LS 273	
IC...42		50.07.0046	CD 4046 BE, MC 14046 BCP ,A RCA,MOT	
IC...43		50.06.0163	SN 74 LS 163	
IC...44		50.06.0151	SN 74 LS 151	
IC...45		50.16.0114	MC 68A52 P ,A	
IC...46		50.16.0113	MC 68A40 P ,A	
IC...52		50.16.0107	MC 6803-1, HD 6803P-1 ,A MOT,HI	
IC...53		50.06.0086	SN 74 LS 86	
IC...54		50.06.0000	SN 74 LS 00	
IC...55		50.06.0138	SN 74 LS 138	
IC...56		50.06.0139	SN 74 LS 139	
IC...61		50.05.0203	SN 75 463 JG, DS 75 463	
IC...62		50.06.0645	SN 74 LS 645	
IC...72		50.06.0541	SN 74 LS 541	
IC...73		50.06.1573	SN 74 ALS 573	
IC...74		50.14.0133	HM 6264 LP-4,SRAM 8K X 8, 200NSEC	
IC...75		50.14.0125	SEE NOTE HM 4827128 G-25, EPROM 16K X 8, 300NSEC	
K....14		56.02.1003	5 V 1*A 100V/0.5A, Print	
K....17		56.04.0195	6 V 2*U 125V/1.0A, Print	
L.....1		62.01.0115	Wide Band HF-Choke	
P.....1		54.01.0354	Card Connector 3 * 32 Euro Wrap	
RZ....1		57.88.4103	8 * 10K 2%, Single Line	
RZ....2		57.88.4103	8 * 10K 2%, Single Line	
RZ....3		57.88.4332	8 * 3.3K 2%, Single Line	
RZ....4		57.88.4103	8 * 10K 2%, Single Line	
RZ....5		57.88.4103	8 * 10K 2%, Single Line	
SZ...71		55.01.0168	8 * 0N, DIL-Switch	

Notes : Software release 1.812.982.20 (IC 75)

CER = Ceramic, EL = Electrolytic, PET = Met. Polyester

MANUFACTURERS : Di = Dialco
 Hi = Hitachi
 Mot = Motorola
 RCA = RCA Corporation
 St = Studer
 TI = Texas Instruments

1.812.460.20 INTERFACE OTARI MX-80 HST89/04/1200

4.4 Signal description, slave connector A

SLAVE CONTROL A:

Pin	Signal	Type	Description
1	GND		signal ground
2	CAPIN	I in	capstan clock from MX-80
3	CAPOUT	I out	capstan clock to MX-80 (9600 Hz nominal)
4	GND		signal ground
5	PLAY_TLY	I in	PLAY tally
6	STOP_TLY	I in	STOP tally
7	FWD_TLY	I in	FAST FORWARD tally
8	REW_TLY	I in	FAST REWIND tally
9	REC_TLY	I in	RECORD tally
10	PLAY_CMD	I out	PLAY command
11	STOP_CMD	I out	STOP command
12	FWD_CMD	I out	FAST FORWARD command
13	REW_CMD	I out	FAST REWIND command
14	GND		signal ground
15	TACHO	I in	move pulse frequency (200 Hz nominal)
16	MOVDIR	I in	move pulse direction (10w = reverse)
17	GND		signal ground
18	SPEED_A	I in	tape speed A tally
19	SPEED_B	I in	tape speed B tally
20	RECEN	I in	(= SLAVE CONTROL B, pin 2)
21	OFF_TLY	I in	TAPEOUT tally
22	REC_CMD	I out	RECORD command
23	REH_CMD	I out	REHEARSE command (see section 3.2)
24	LIFT_CMD	I out	LIFTER DEFEAT command
25	REMON+		power supply of MX-80 (24V)

signal types: I in logic input, activ low
 I out logic outputs, activ low
 (open collector output, max 28V/0.3A)

4.5 Slave connector B

SLAVE CONTROL B:

Pin	Signal	Type	Description	
1	GND	I in	signal ground	
2	RECEN		record enable/safe (see DIL switches)	
3	-			
4	-			
5	-			
6	REL1		relay contact 1 (100V/0.5A)	
7	REL2		relay contact 2 (100V/0.5A)	
8	-			
9	-			
10	-			
11	-			
12	-			
13	GND	I out	signal ground	
14	GND		signal ground	
15	-			
16	-			
17	-			
18	-			
19	-			
20	-			
21	MVCL		buffered move clock from MX-80 (12.5 Hz nom)	
22	-			
23	-			
24	MVDR		I out	buffered move direction (low = reverse) power supply from MX-80
25	REMON+			

signal types:

I in

logic input with internal pullup
driven by switch, o.c. or active driver
activ: < 1V inactive: 2..30V or open-

I out

logic output
(open collector output, max 28V/0.3A)

4.6 IF cable (drawing, wiring list)

TLS 4000
SLAVE CONTROL A

OTARI MX-70/80
PARALLEL I/O

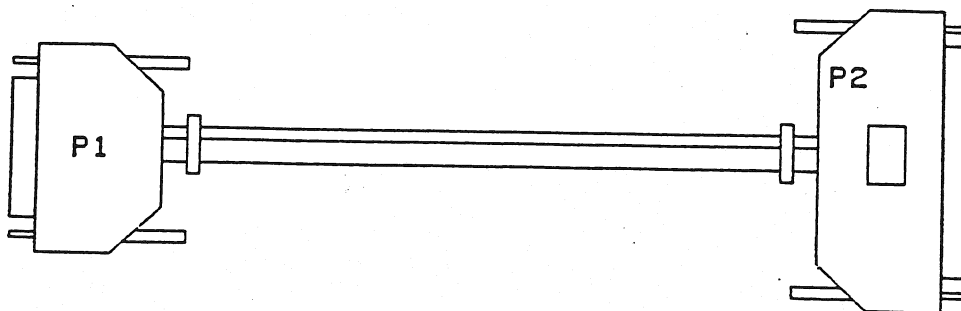

P1.10.....	PLAY_CMD	P2.2
11.....	STOP_CMD.....	3
12.....	FWD_CMD.....	4
13.....	REW_CMD.....	5
22.....	REC_CMD.....	1
24.....	LIFT_CMD.....	6
23.....	REH_CMD.....	32
17.....	GND.....	23
5.....	PLAY_TLY.....	11
6.....	STOP_TLY.....	12
7.....	FWD_TLY.....	13
8.....	REW_TLY.....	14
9.....	REC_TLY.....	10
21.....	OFF_TLY.....	9
18.....	SPEED_A.....	21
19.....	SPEED_B.....	22
25.....	REMON_+.....	34
4.....	GND.....	16

2.....	CAPIN.....	19
3.....	CAPOUT.....	20
15.....	TACHO.....	17
16.....	MOVDIR.....	18
14.....	SHIELD.....	N/C

© 28/07/89 MST	○	○	○	○
	TLS4000			PAGE 1 OF 1
STUDER	IF-KABEL OTARI MX-70/80	5M	Z	1.023.764.00